

**A**  
[WITHOUT  
START RELAY]

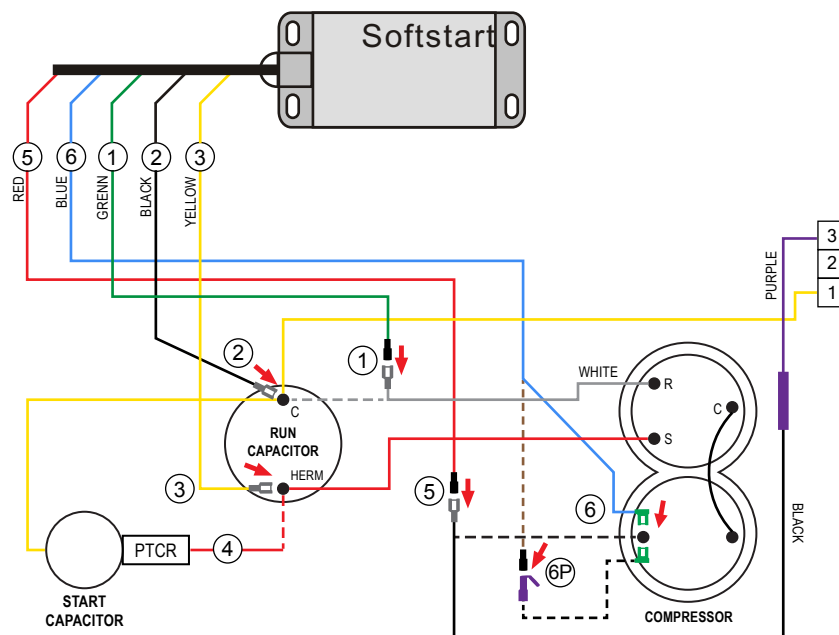

**B**  
[INCLUDES  
START RELAY]

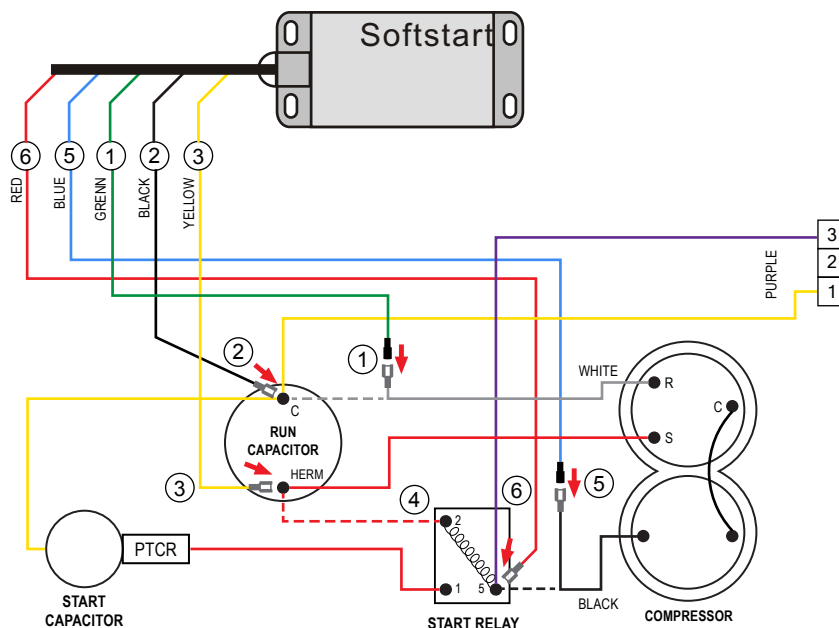

**TURN ALL POWER OFF BEFORE STARTING INSTALLATION.**

**A** Route Blue, Black and Yellow SoftStart wires into the electrical box. Route the Brown and Red wires to the top of the Compressor. Crimp connectors onto ends of SoftStart wires as indicated in drawing.

Step ① Follow White Compressor wire from Compressor to Run Capacitor. Disconnect from terminal and connect it to Green SoftStart wire. Seal connection with electrical tape.

Step ② Connect Black SoftStart wire to the terminal that the White Compressor wire was on.

Step ③ Connect Yellow SoftStart wire on terminal next to Red Compressor wire on HERM side of Run Capacitor.

Step ④ **IF** there is a second Red wire next to Red Compressor wire on HERM side of Run Capacitor, disconnect it, seal end with tape and drop it.

Step ⑤ Remove the Compressor Cap. Disconnect Black wire and connect to Red SoftStart wire. Tape connection. **Do not put wires back under cap.**

Step ⑥ Connect Blue SoftStart wire (with Female Flag connector) onto the terminal that the Black Compressor wire was on. Route Blue SoftStart wire out with Red and White Compressor wires. Replace cap.

Step ⑥P [OPTIONAL] Connect Female Flag end of 4" PigTail onto the terminal that the Black Compressor wire was on. Crimp Male connector onto Blue SoftStart wire, then connect it to Female side of Piggyback connector. Break off unused tangent from Piggyback connector. Route Pigtail wire out with Red and White wires and replace cap.

**B** Route all SoftStart wires into the electrical box. Crimp connectors onto ends of SoftStart wires as indicated in drawing.

Repeat Steps 1 through 4 from instructions above.

Step ⑤ Follow Black Compressor wire to the Start Relay and disconnect it. Connect Black wire to the Brown SoftStart wire. Tape connection.

Step ⑥ Connect the Red SoftStart wire onto the terminal that the Black Compressor wire was on.

Turn Power and A/C Breaker on. Turn A/C to Auto Cool setting and set the thermostat to 55°F.

Look at SoftStart LED lights. Green light should be "on". Green light means the Compressor is running (there may be a full 3-minute delay before Green light comes on). **IF there is no Green light after 4 minutes**, please check the error code or contact us for assistance.

Re-install all A/C covers.

Turn A/C on, set near to outdoor temperature and run for 30 minutes.

After 30 minutes, operate A/C normally.